



*Technical University of Liberec
Faculty of Textiles
Department of Nonwoven Textiles
Czech Republic*



NEEDLELESS ELECTROSPINNING USING LINEAR AND CIRCULAR CLEFTS

*Aina Garg, Jasleen Bhasin, Kshitij Sachar,
Petr Mikeš, Kateřina Vodsed'álková, Jiří
Chvojka
and David Lukáš,*

Overview

- Needle and needleless electrospinning
- Needleless Electrospinning Technology
- Intra-jet distance and **relaxation time**
- Experimental
- Relaxation time – field strength relationships
- Conclusion



Allegory of Age Governed by Prudence (c. 1565–1570) is thought to depict Titian
TITIAN. (Tiziano Vecelli) 1485-1586

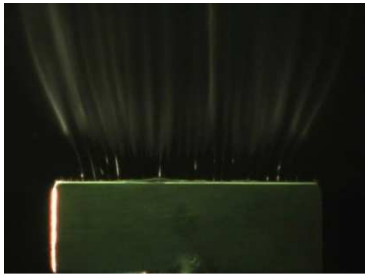
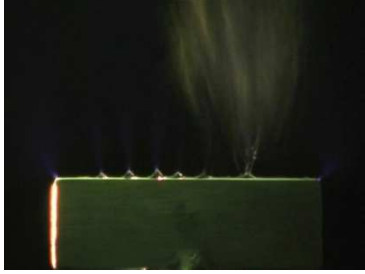
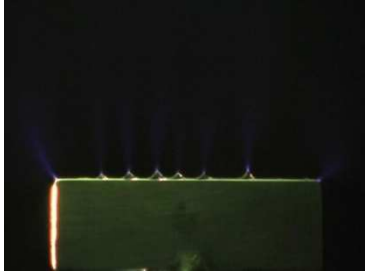
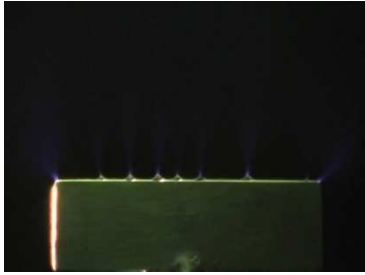
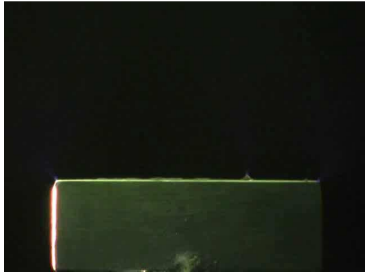



Needle electrospinning

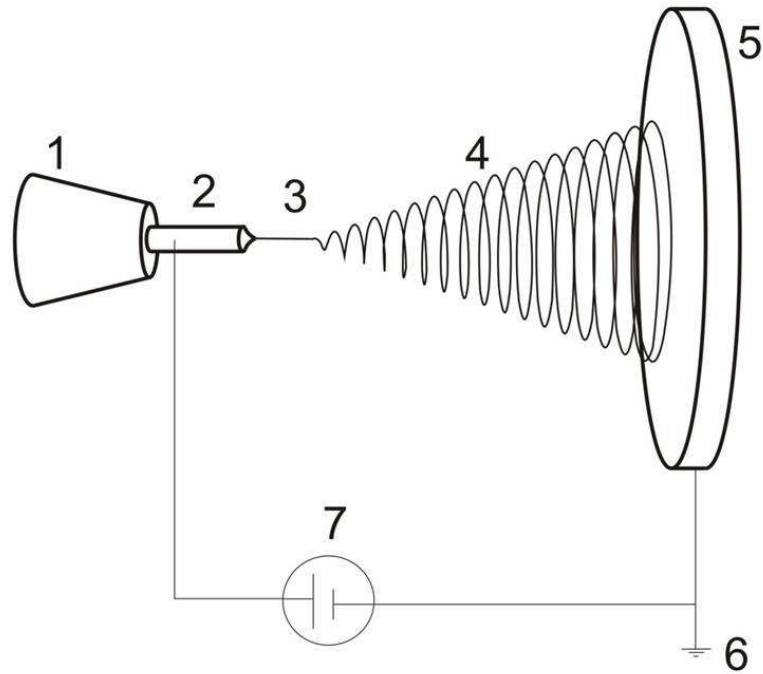

Needleless electrospinning

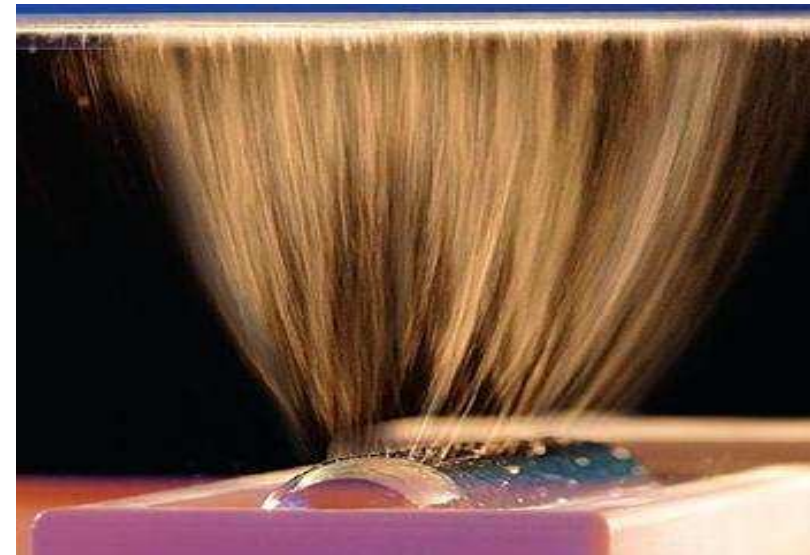
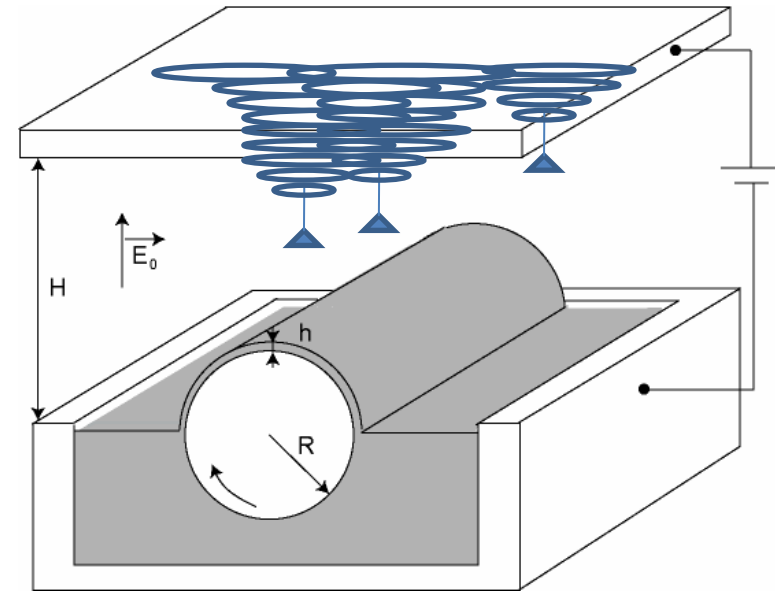

Intra/jet distances and time delay

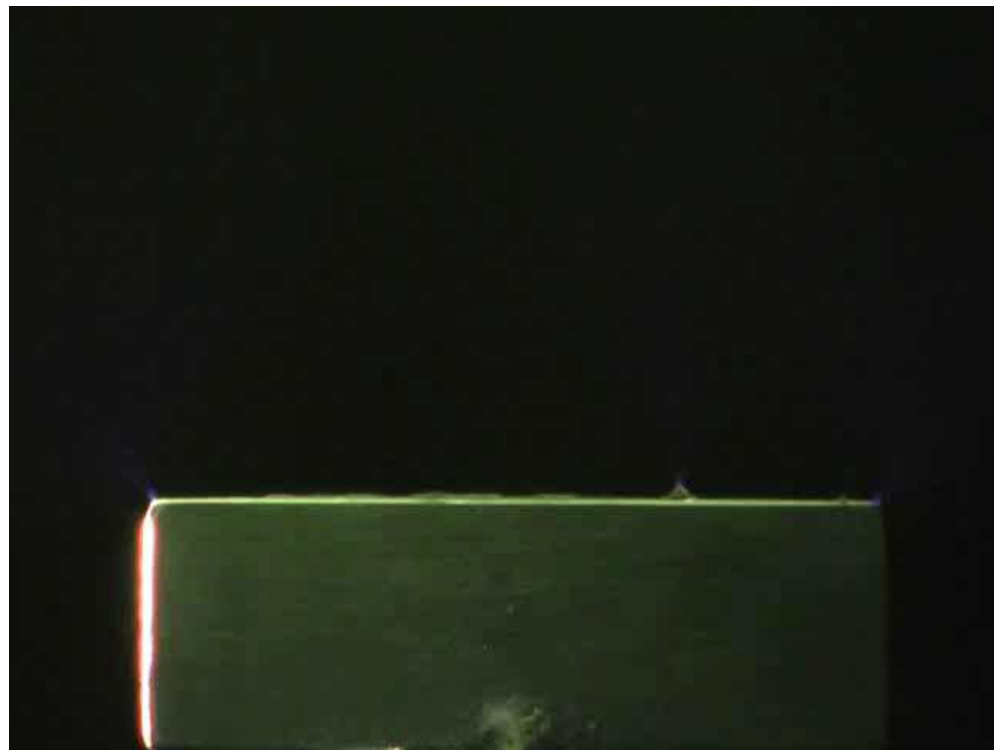
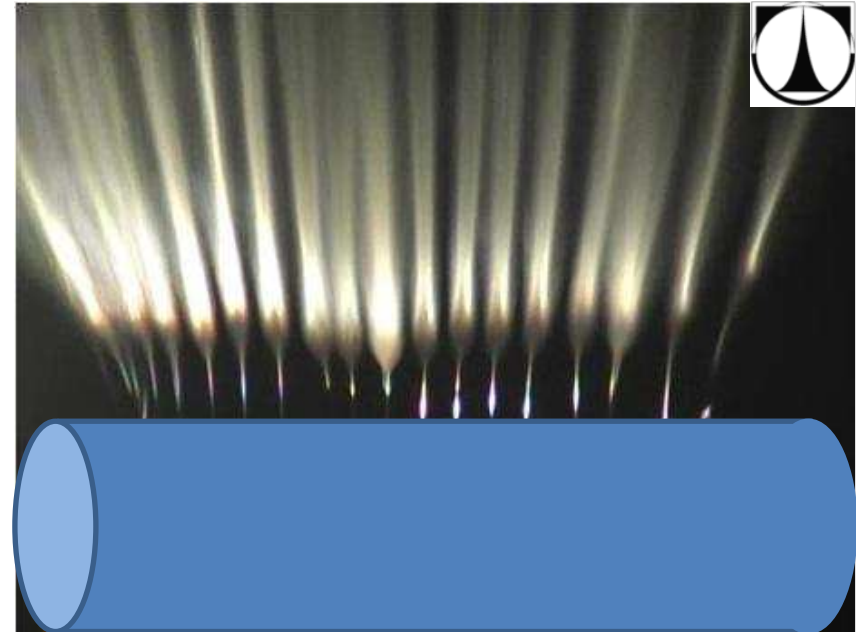
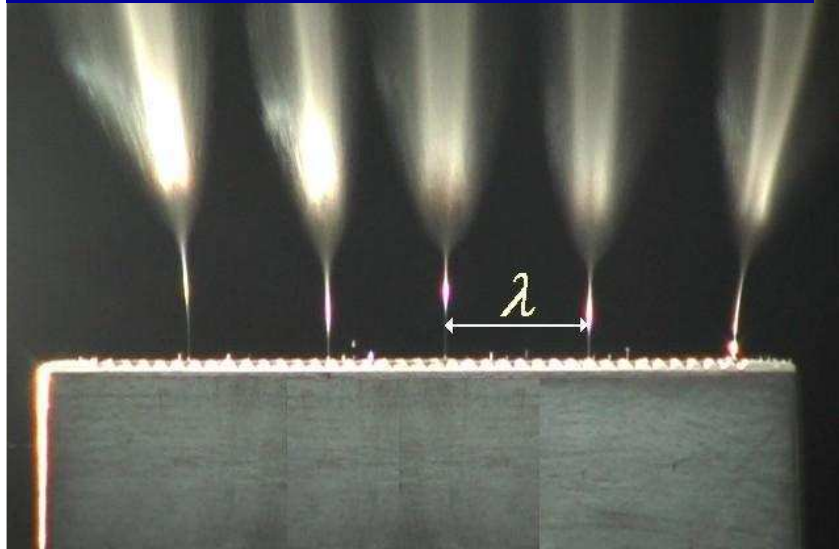



$$\lambda = \frac{12\pi\gamma}{2\varepsilon E_0^2 + \sqrt{(2\varepsilon E_0^2)^2 - 12\gamma\rho g}}$$

$$\Gamma = \frac{a\varepsilon E_0^2}{2\gamma}$$

Electrospinning number

$$\Lambda = \frac{\lambda}{a} = \frac{3\pi}{\Gamma + \sqrt{\Gamma^2 - 3/4}}$$

$$K = ak = \frac{2\pi}{\Lambda}$$

Dimensionless wave number

Dimensionless wave length

Dimensionless relaxation time

$$T = \frac{\tau}{\sqrt{a/g}} = \sqrt{\frac{3}{2K(K\Gamma - 1)}}$$

Needleless Electrospinning

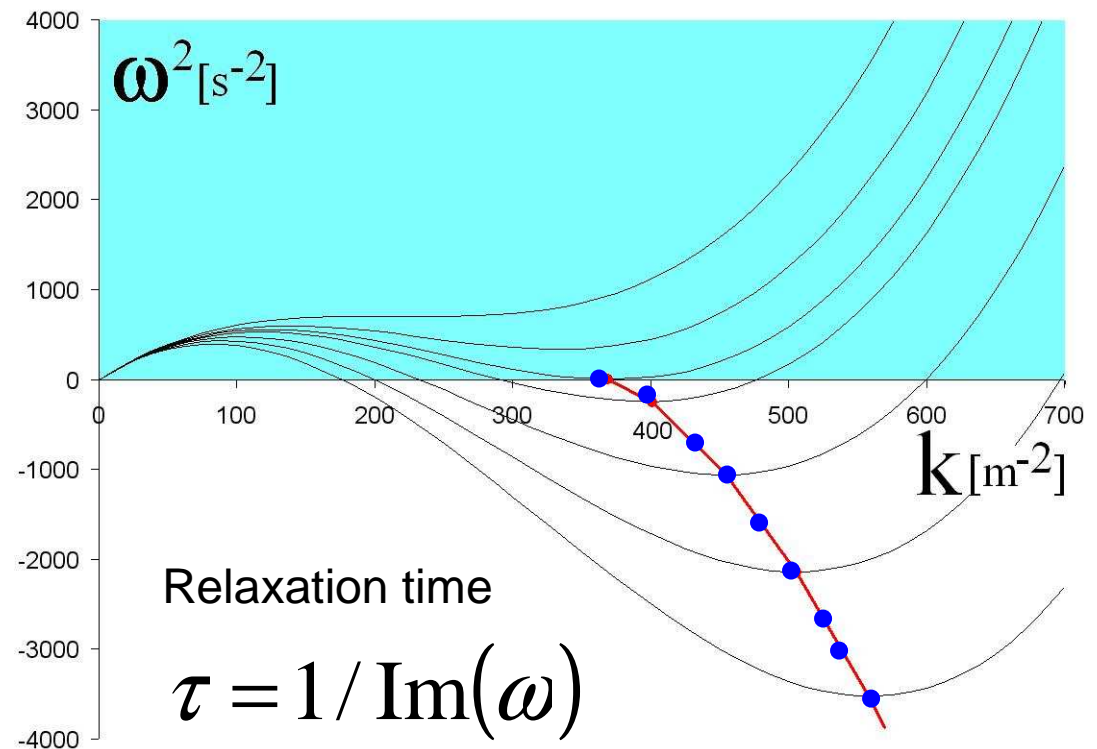

Physical rules

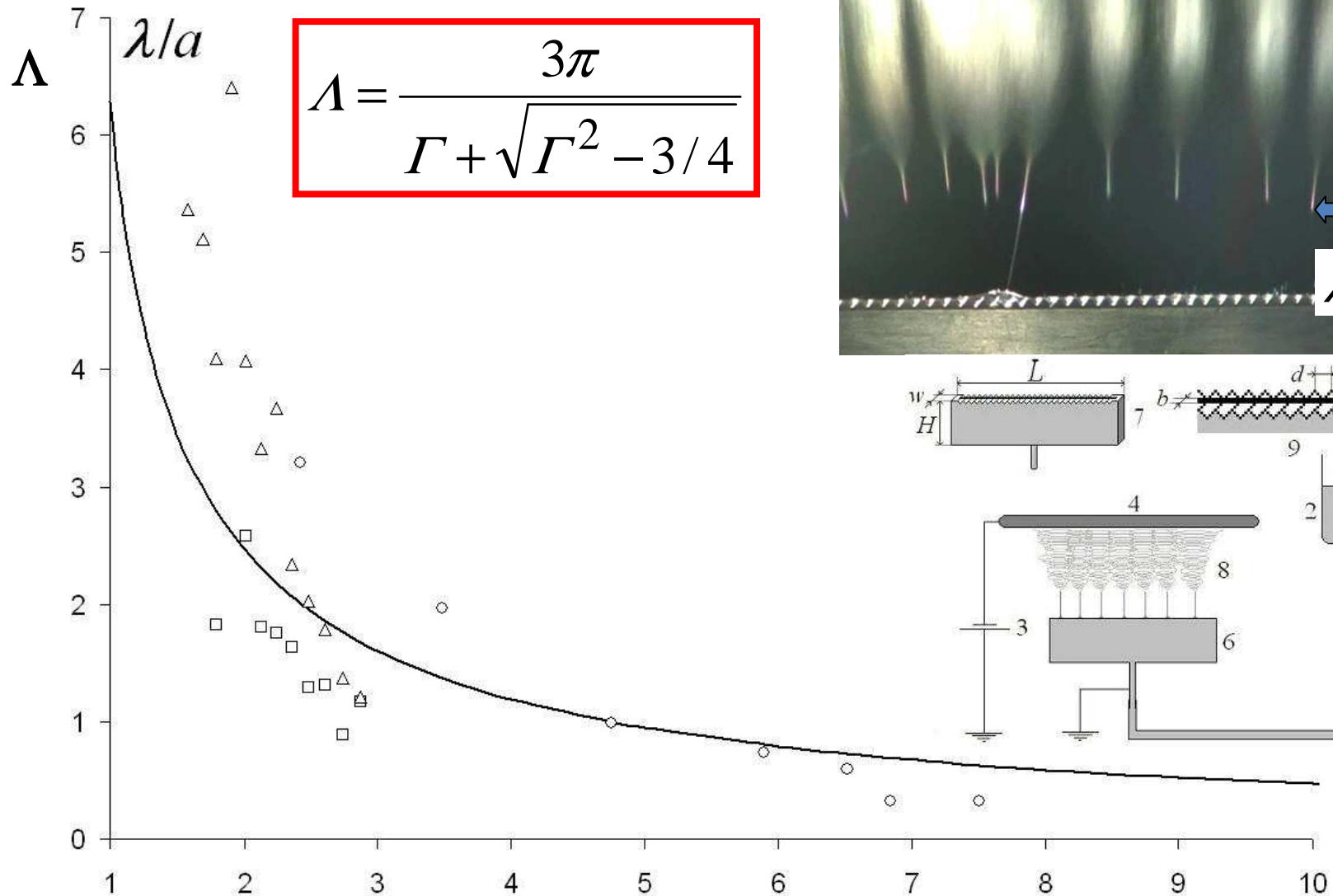

Universal curve showing dependency of the dimensionless wavelength, Λ , on the electrospinning number, Γ :

$$\frac{1}{T} = \text{Im}(\omega)$$

$$\xi(x, t) = Ae^{\text{Im}(\omega)t} \exp[i(kx \text{ } \square)]$$

Growing amplitude
Growing parameter

ω is imaginary $\leftarrow \omega^2 < 0 \leftarrow E > E_c$

Relaxation time

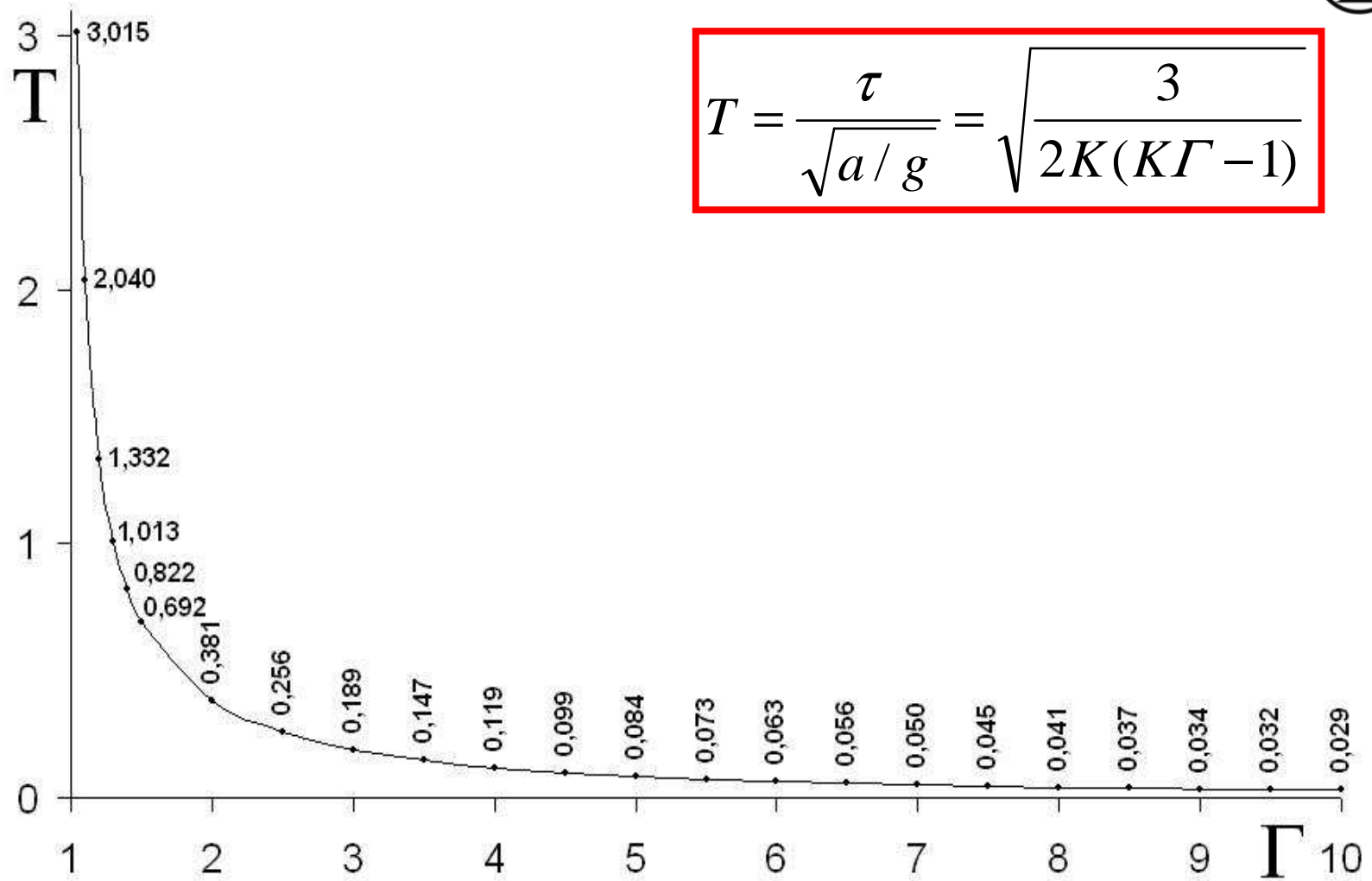

Universal curve showing dependency of dimensionless relaxation time, T , on the electrospinning number, Γ .

Experimental

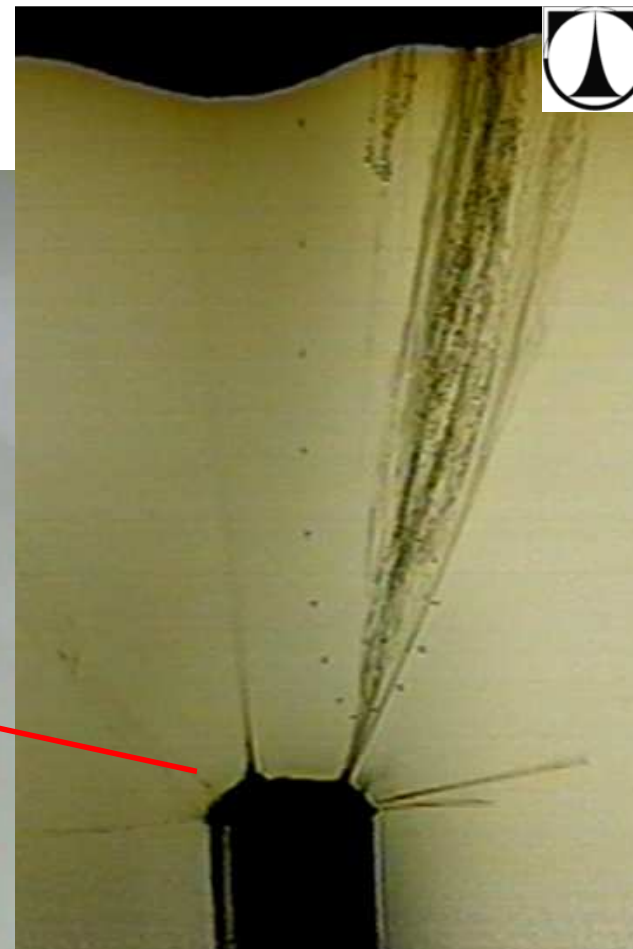
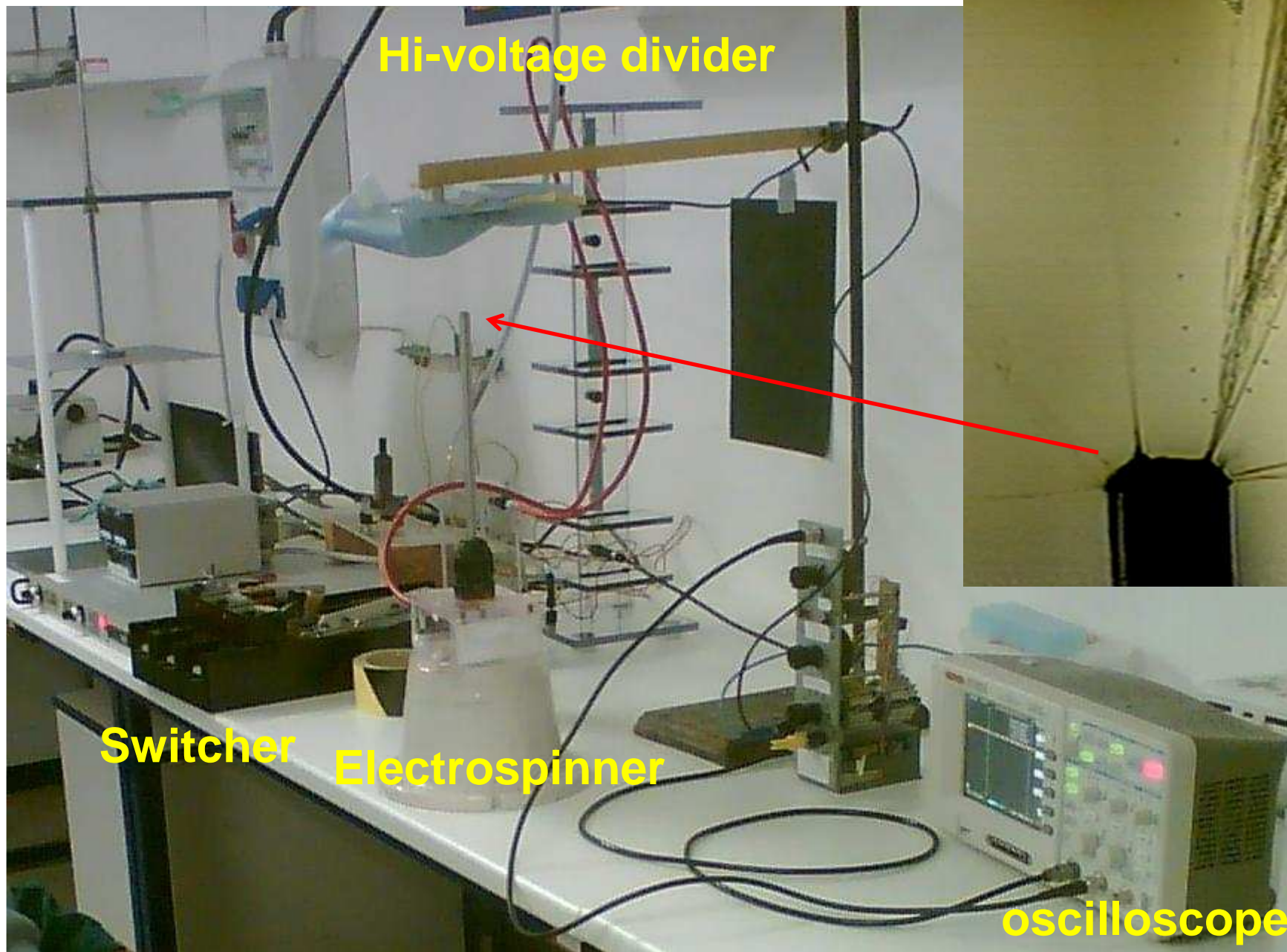

Experimental

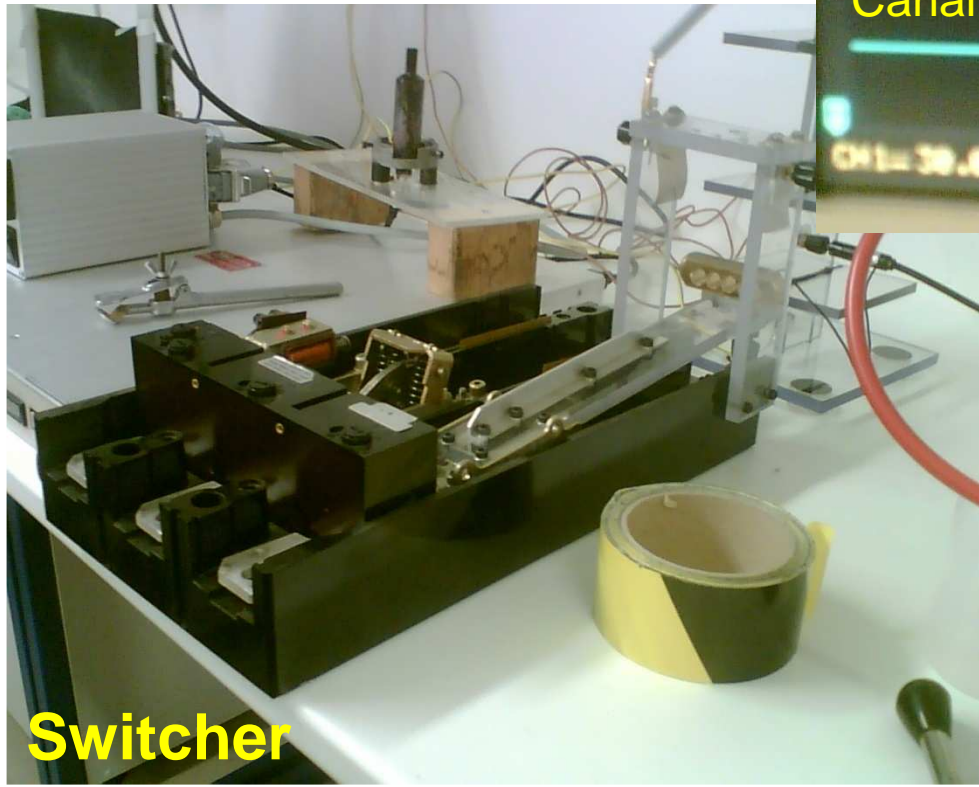
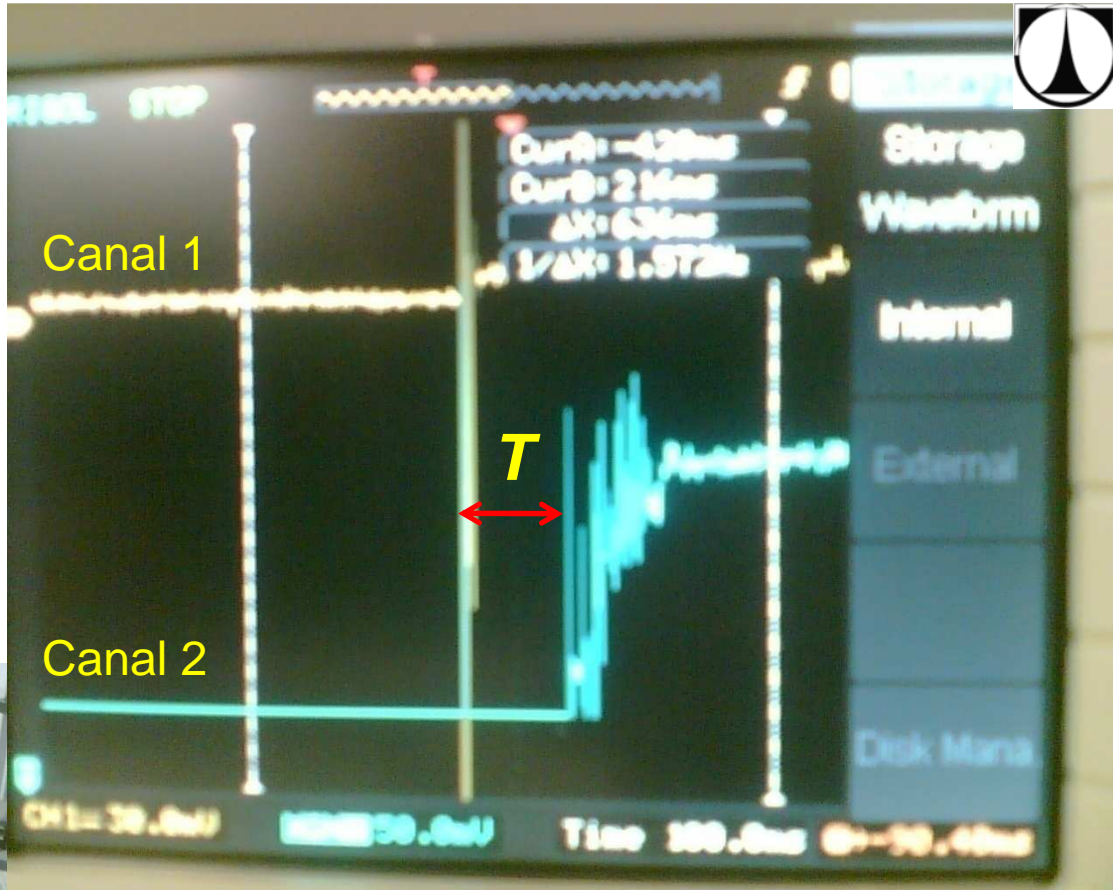



Voltage – time

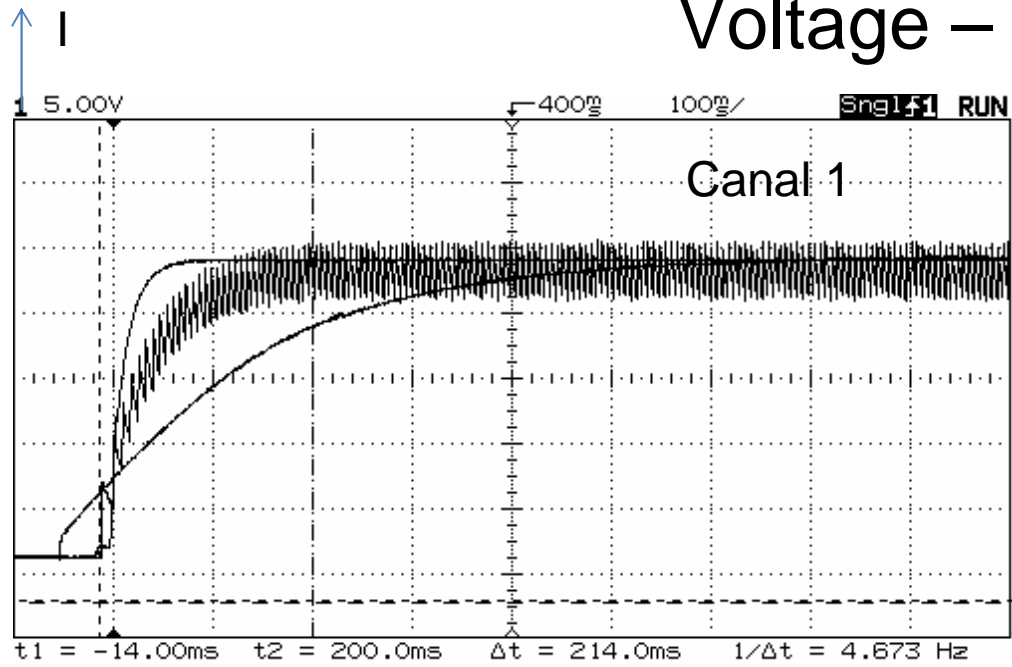

Run-up voltage-time dependences:

- MATSUSADA cca
- 70 ms
- GLASSMANN cca
- 200 ms
- SPELLMANN cca

I-t record of Taylor cone first appearance:

600 ns

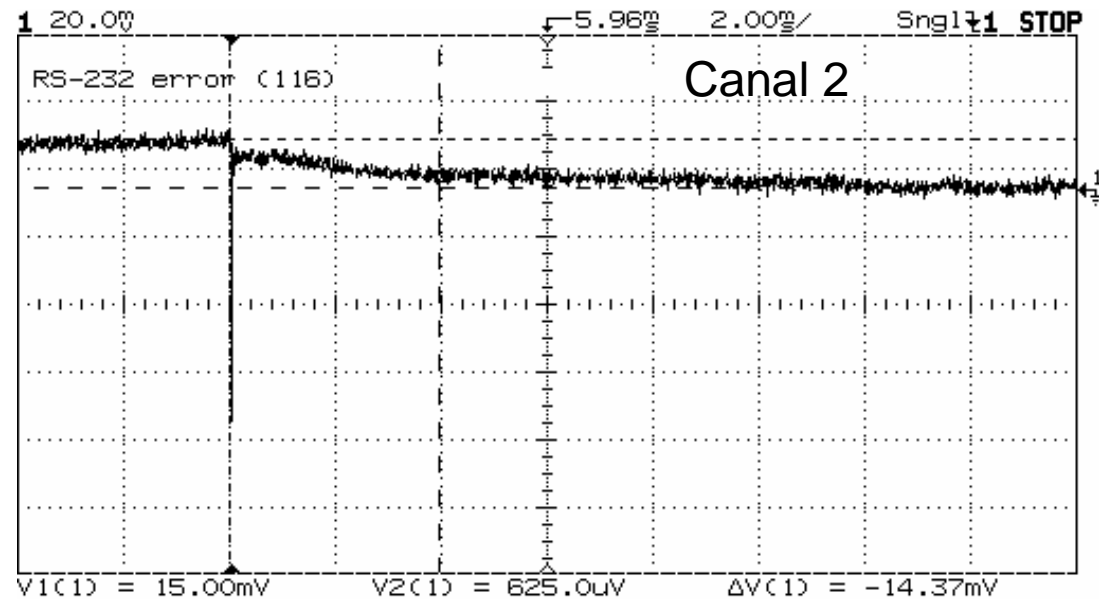

Relationships



Time – Field Strength

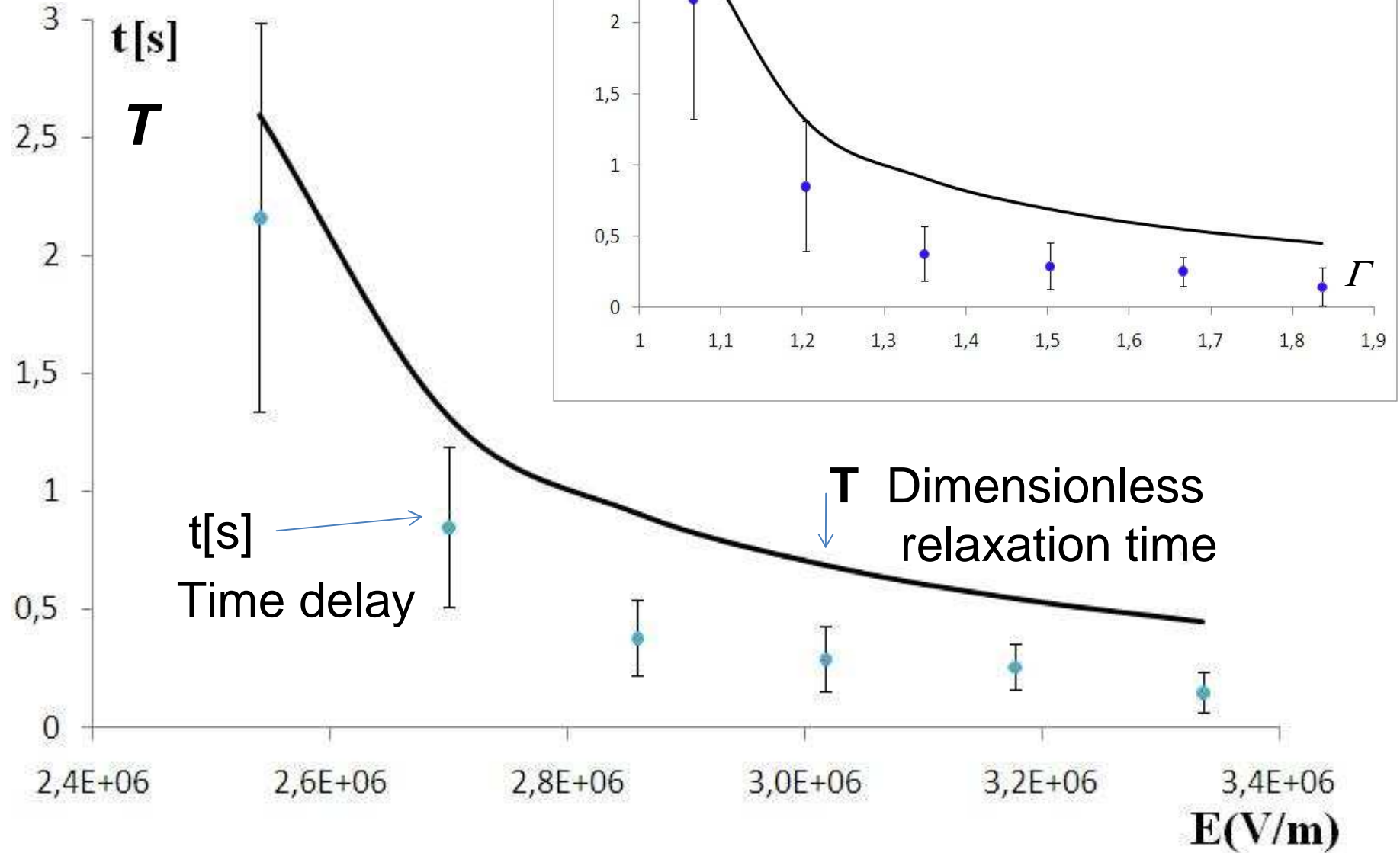

Relationships



Time delay – dimensionless relaxation time

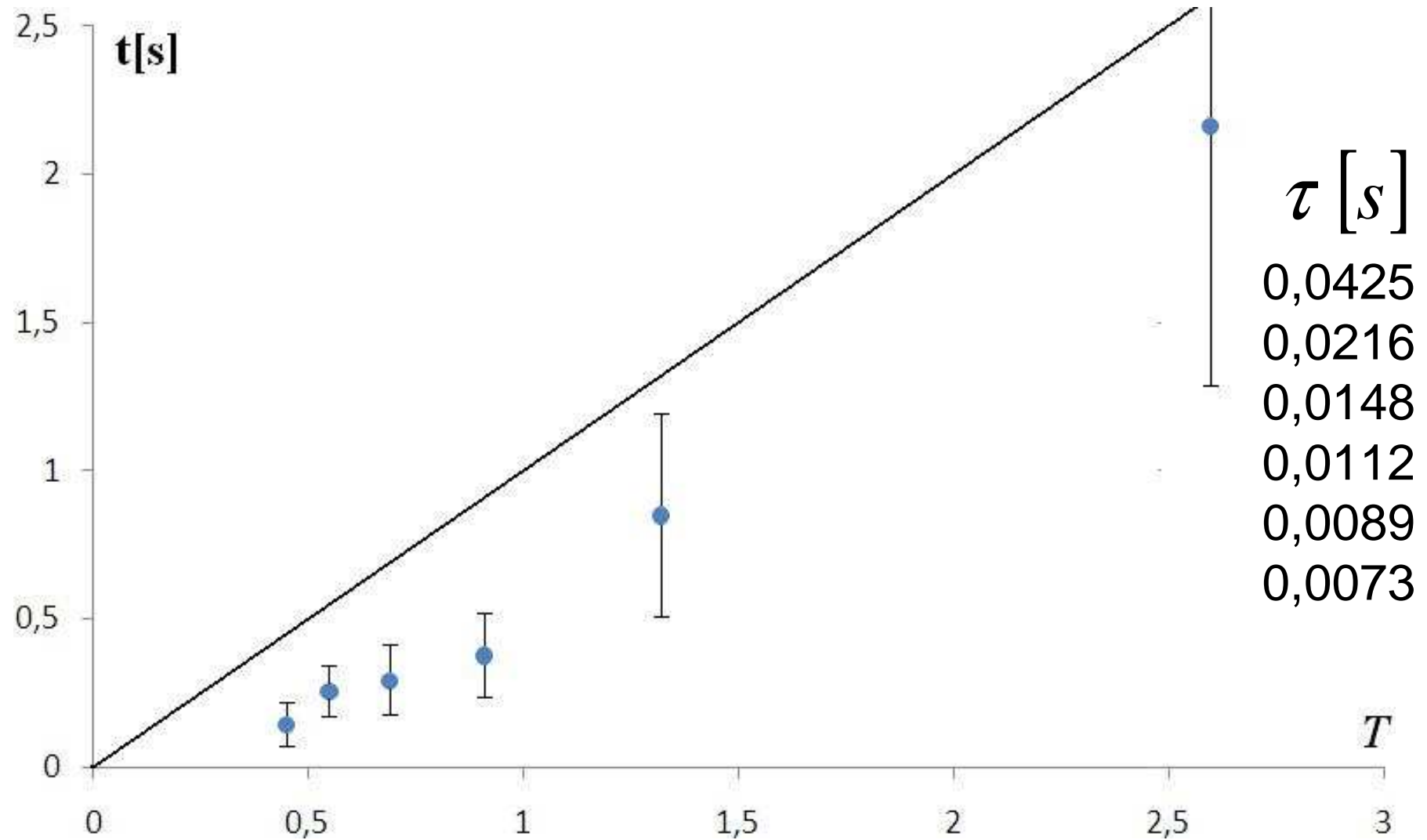

Conclusion:



- New analytical tool for electrospinning investigation